



HYDRAULIC MOTOR REDUCTION UNIT MG5-V



TYPE		MGV5					
SIZE		300	400	500	630	800	960
DISPLACEMENT per OUTPUT rpm	cm ³	1540.0	1910.0	2500.0	3145.0	4005.0	4800.0
	in ³	94.0	119.0	152.5	192.0	244.5	293.0
MAX. OUTPUT SPEED	rpm cont.	102	100	80	63	50	40
	rpm int.	126	120	96	76	60	50
MAX. OUTPUT TORQUE	Nm cont.	4600	5900	7300	8300	9375	7475
	lbf.in cont.	40710	52215	64605	73455	82968	66153
	Nm int.	5550	7050	8800	9700	10550	10625
	lbf.in int.	49117	62392	77880	85845	93367	94031
MAX. PRESSURE DROP	bar cont.	175	175	175	180	160	105
	psi cont.	2540	2540	2540	2610	2320	1522
	bar int.	240	240	240	210	180	150
	psi int.	3480	3480	3480	3045	2610	2175
MAX. OIL FLOW	lpm cont.	160	190	200	200	200	190
	gpm cont.	35	42	44	44	44	42
	lpm int.	195	230	240	240	240	240
	gpm int.	43	51	53	53	53	53

Maximum continuous output torque 9375Nm 82968lbf.in

Reduction Ratio 5:1

Basic Motor Detail

Mineral based hydraulic fluids with anti-wear additives are recommended with a viscosity of 35 mm²/s at a temperature of 50°C.

Minimum recommended oil viscosity 13 mm²/s at operating temperature.

Recommended oil cleanliness ISO 19/14 with a nominal filtration of 25micron or better.

Where non-flammable fluids are to be used it is advisable to consult our Technical Department.

Ambient temperature should be between -30°C and +90°C.

Normal operating temperature should be between +30°C and +60°C.

Maximum operating temperature +85°C.

The policy of Adan Limited is one of continual development and the right is reserved to alter specifications without notice.



ADAN LIMITED

RIVERSIDE IND. ESTATE BOSTON LINCOLNSHIRE ENGLAND

Tel: +44 (01205) 311500

email: sales@adanltd.co.uk

Fax: +44 (01205) 358013

website: www.adanltd.co.uk



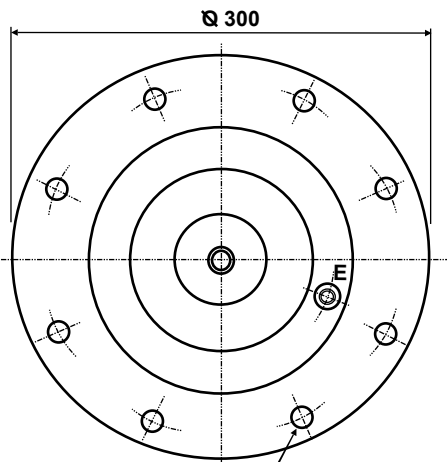

8 HOLES EQUI-SPACED ON 270 PCD
DRILL Ø 12.5 THRU

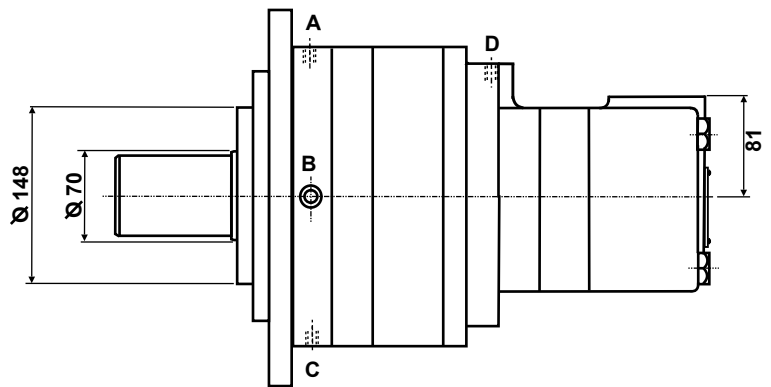
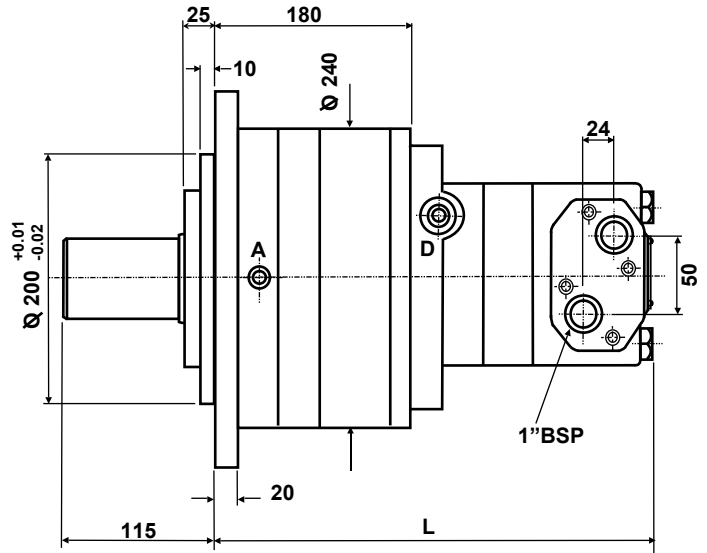
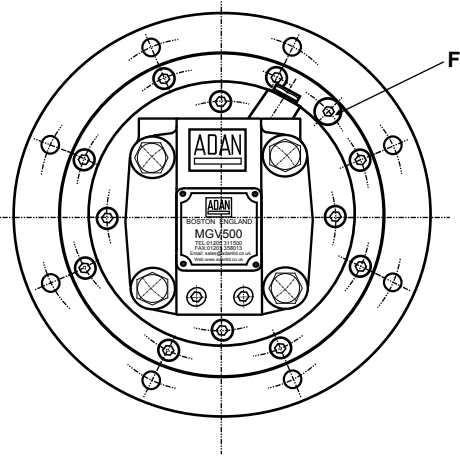

Ports A,B,C,D,E & F alternative gearbox drain connections 1/4" BSP. Standard units supplied with five plugs & transit plug. For sealed units four ports plugged the other fitted with a breather.

For Motor performance see MV performance graphs

MGV-5	300	400	500	630	800	960
DIM ^N L mm	358	364	374	384	398	411
WEIGHT Kg	95	96	97	98	100	104

SHAFT VARIANTS

MGV SERIES

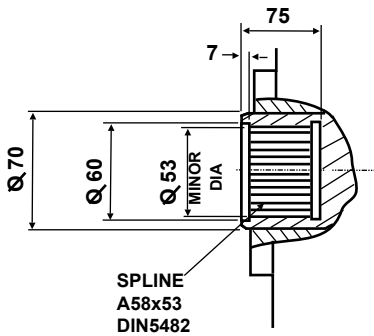

SHAFT TYPE 'F'

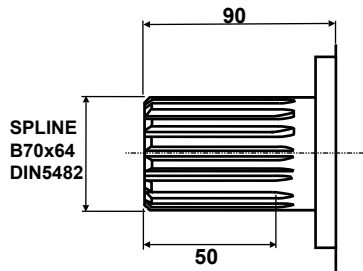

SHAFT TYPE 'SP'

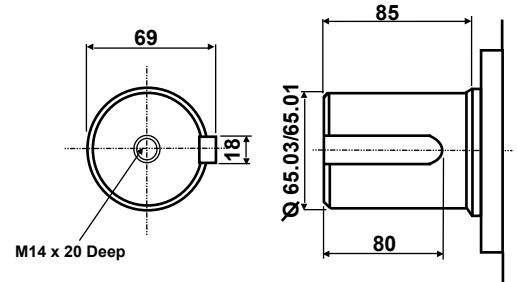

SHAFT TYPE 'M'

SHAFT ROTATION

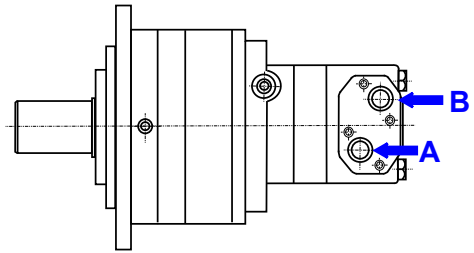
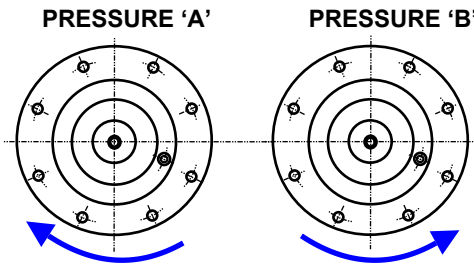

MOUNTING POSITIONS

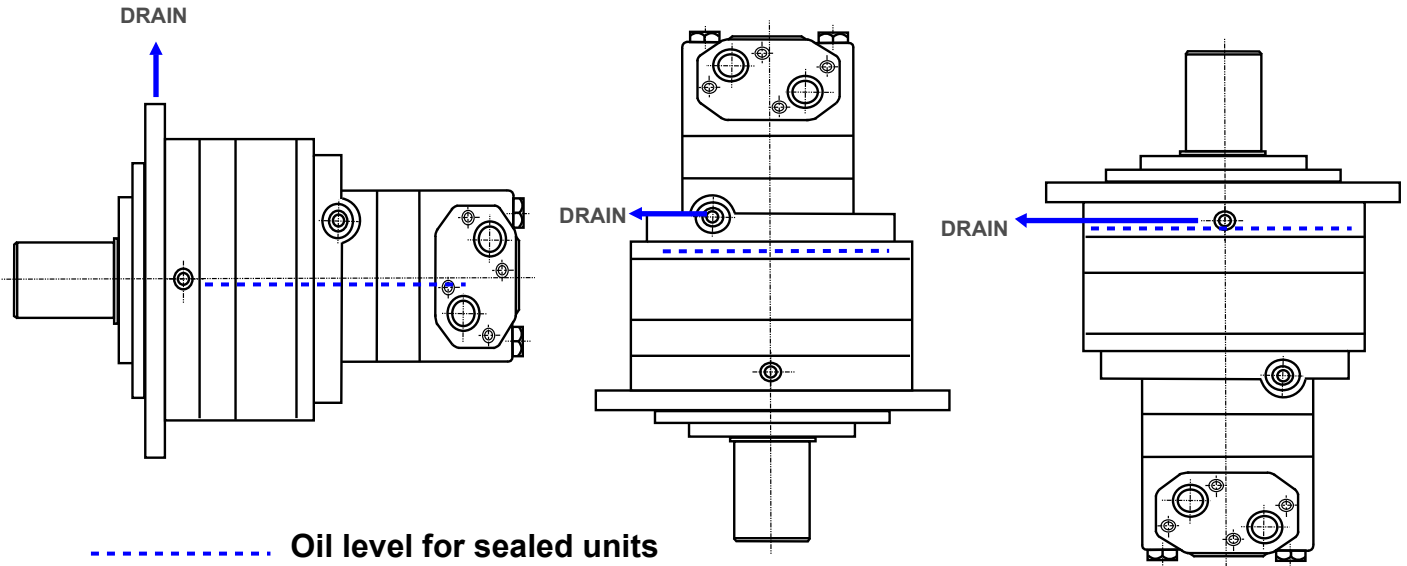

..... Oil level for sealed units

Standard units must be drained to tank from the highest point as shown. Sealed motor units fit breather in highest point and fill gearbox to level indicated using an EP oil with anti foaming additives, Select the grade appropriate to temperature from the chart based on ISO 3448. It is recommended to replace oil after first 50 hours, then every 1000 hours or 6 months.

Viscosity	Ambient Temperature °C
ISO VG 150	-10 > +30
ISO VG 220	+10 > +45
ISO VG 320	+30 > +60

ORDERING CODE

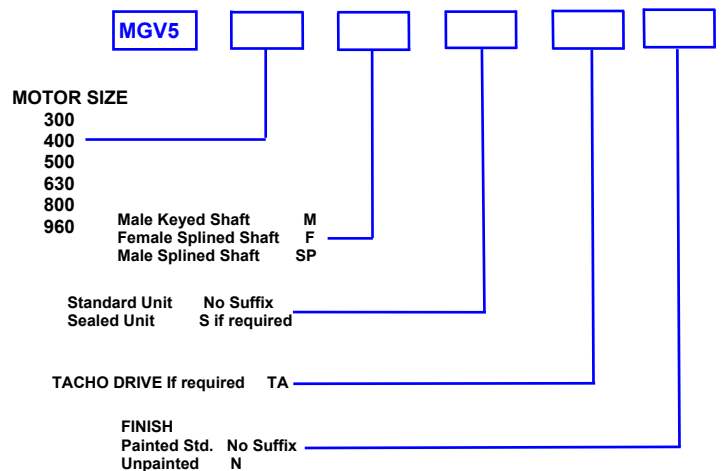

The policy of Adan Limited is one of continual development and the right is reserved to alter specifications without notice.



ADAN LIMITED

RIVERSIDE IND. ESTATE BOSTON LINCOLNSHIRE ENGLAND
 Tel: +44 (01205) 311500 Fax: +44 (01205) 358013
 email: sales@adanltd.co.uk website: www.adanltd.co.uk

