

ANCILLARY EQUIPMENT

MXR15W

MOTOR MOUNTED CROSS PORT RELIEF VALVES FOR V & W SERIES MOTORS

MOTOR MOUNTED CROSS PORT RELIEF VALVE FOR AWMP / AVMP SERIES MOTORS

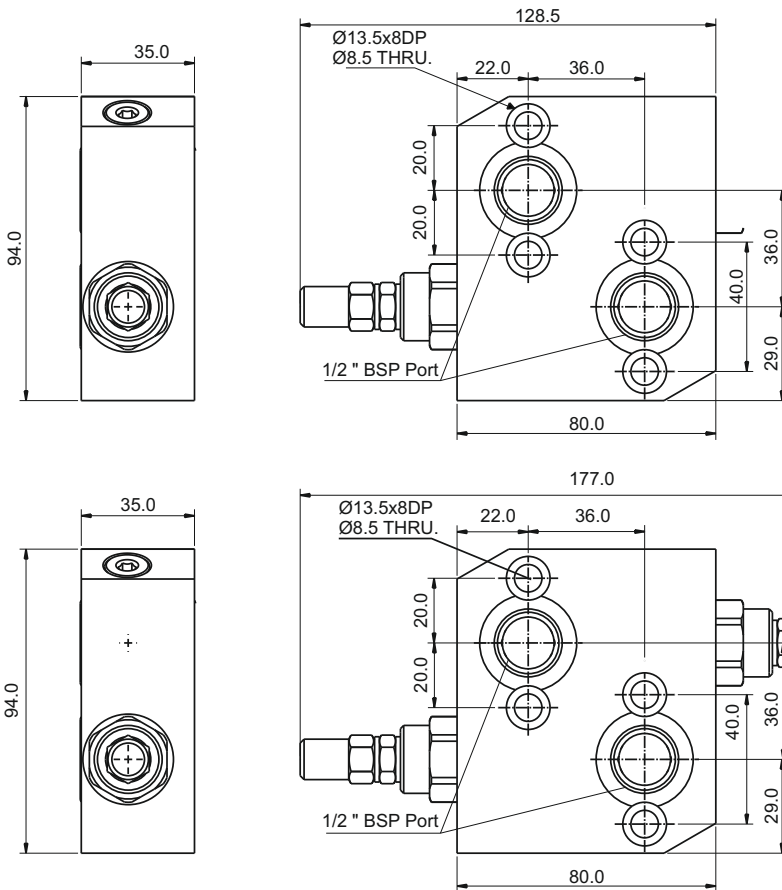

ORDERING CODE

MXR 15W **D** **50**

Type

Number of valves:

- D - Double
- SA - Single valve on A Side
- SB - Single valve on B Side

Sprint Options

Order Code	Pressure Setting Range (Bar)	Pressure Increase (Bar/turn)	Standard Setting (Bar)
50	10 - 50	7	30
100	20 - 100	12	75
-Omit (Std)	10 - 180	30	90
250	50 - 250	45	130
300	80 - 300	50	150

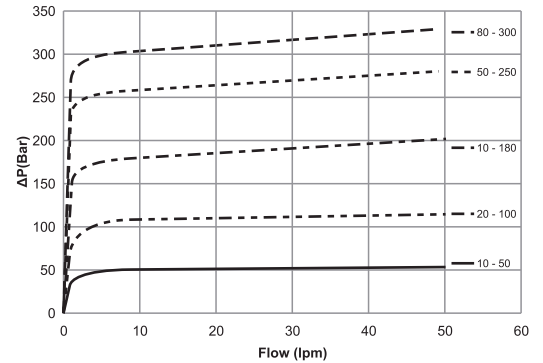

D - Double

SA - Single valve on A Side

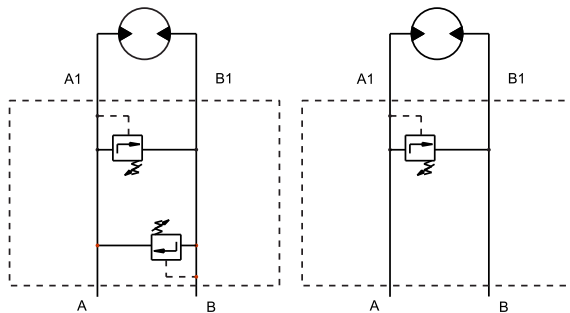

Maximum Pressure : 300 Bar

Rated Nominal Flow : 60 lpm

Mineral based Hydraulic fluids with anti-wear additives are recommended with a viscosity of 35cSt at a temperature of 50° C.

Recommended oil cleanliness ISO 19/14 with a nominal filtration of 25 micron or better.

Tightening torque for mounting screws 20 Nm

The policy of Adan Limited is one of continual development and the right is reserved to alter specifications without notice.



ADAN LIMITED

RIVERSIDE IND. ESTATE BOSTON LINCOLNSHIRE ENGLAND

Tel: +44 (0)1205) 311500

email: sales@adanltd.co.uk | website: www.adanltd.co.uk



ANCILLARY EQUIPMENT

OCV15W

MOTOR MOUNTED OVER CENTRE
VALVE FOR V&W SERIES MOTORS

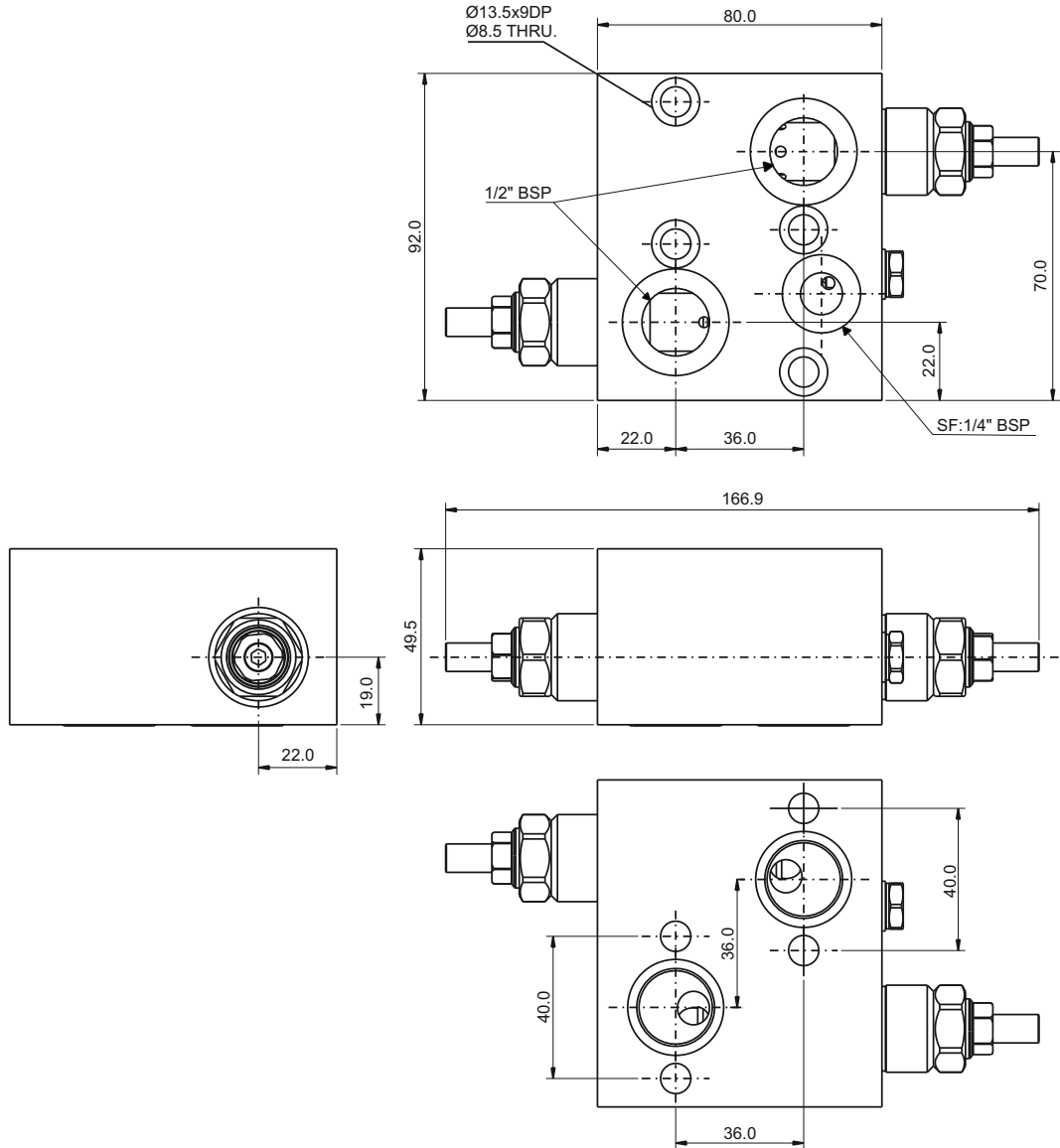

Maximum pressure 280 bar 4060 psi
 Pressure range 60-280 bar 870-4060 psi
 Maximum rated flow 60 lpm
 Pilot ratio 4.25:1
 Valve supplied complete with mounting screws & 'o' rings.
 Valves are not pre-set
 Should a set pressure be required please state at time of order.

Mineral based Hydraulic fluids with anti-wear additives are recommended with a viscosity of 35 mm²/s at a temperature of 50°C.
 Recommended oil cleanliness ISO 19/14 with a nominal filtration of 25 micron or better.
 Steel body and valve sections.
 Tightening torque for mounting screws 17 Nm

WEIGHT 3 kg

The policy of Adan Limited is one of continual development and the right is reserved to alter specifications without notice.



ADAN LIMITED

RIVERSIDE IND. ESTATE BOSTON LINCOLNSHIRE ENGLAND

Tel: +44 (01205) 311500

email: sales@adanltd.co.uk | website: www.adanltd.co.uk



VALVE DETAILS

OPERATION

The check valve section allows free flow into the actuator, then holds and locks the load against movement. The pilot assisted relief valve section will give controlled movement when pilot pressure is applied. The relief section is normally set to open at a pressure of at least 1.3 times the maximum load induced pressure but the pressure required to open the valve and allow movement depends on the pilot ratio of the valve. The pressure required to open the valve and start movement can be calculated as follows:-

$$\text{Pilot Pressure} = \frac{(\text{Relief Setting}) - (\text{Load Pressure})}{(\text{Pilot Ratio})}$$

Example:- Pilot Ratio 4.25:1 Relief set at 145 bar (2100psi) and a load pressure of 114 bar (1650 psi)

$$\frac{145\text{bar (2100psi)} - 114\text{bar (1650psi)}}{4.25} = 7.3\text{bar (105psi)}$$

Any increase in pilot pressure will result in an increase in load velocity and a reduction in pilot pressure, slowing and stopping load movement. When used with an open centre directional valve it will allow thermal expansion relief of the hydraulic fluid.

These motor mounted valves have the load control of dual overcentre valves with the additional advantage of a brake release shuttle valve for smooth safe performance.

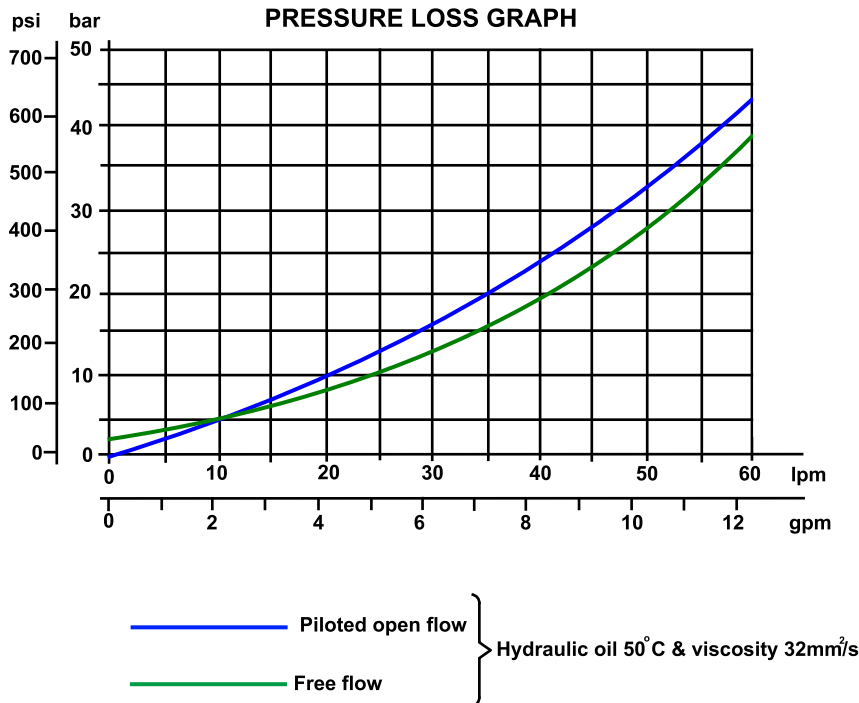
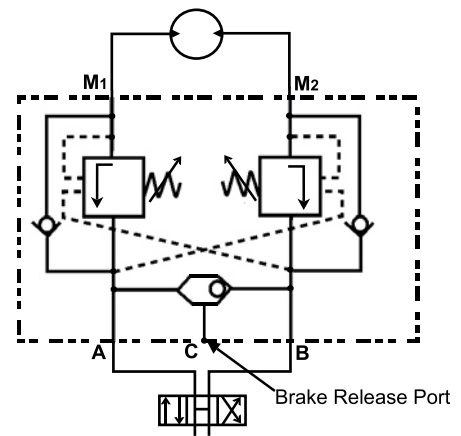

The policy of Adan Limited is one of continual development and the right is reserved to alter specifications without notice.



ADAN LIMITED
 RIVERSIDE IND. ESTATE BOSTON LINCOLNSHIRE ENGLAND
 Tel: +44 (01205) 311500
 email: sales@adanltd.co.uk | website: www.adanltd.co.uk

